

## Question

Consider the following bilateral control system:

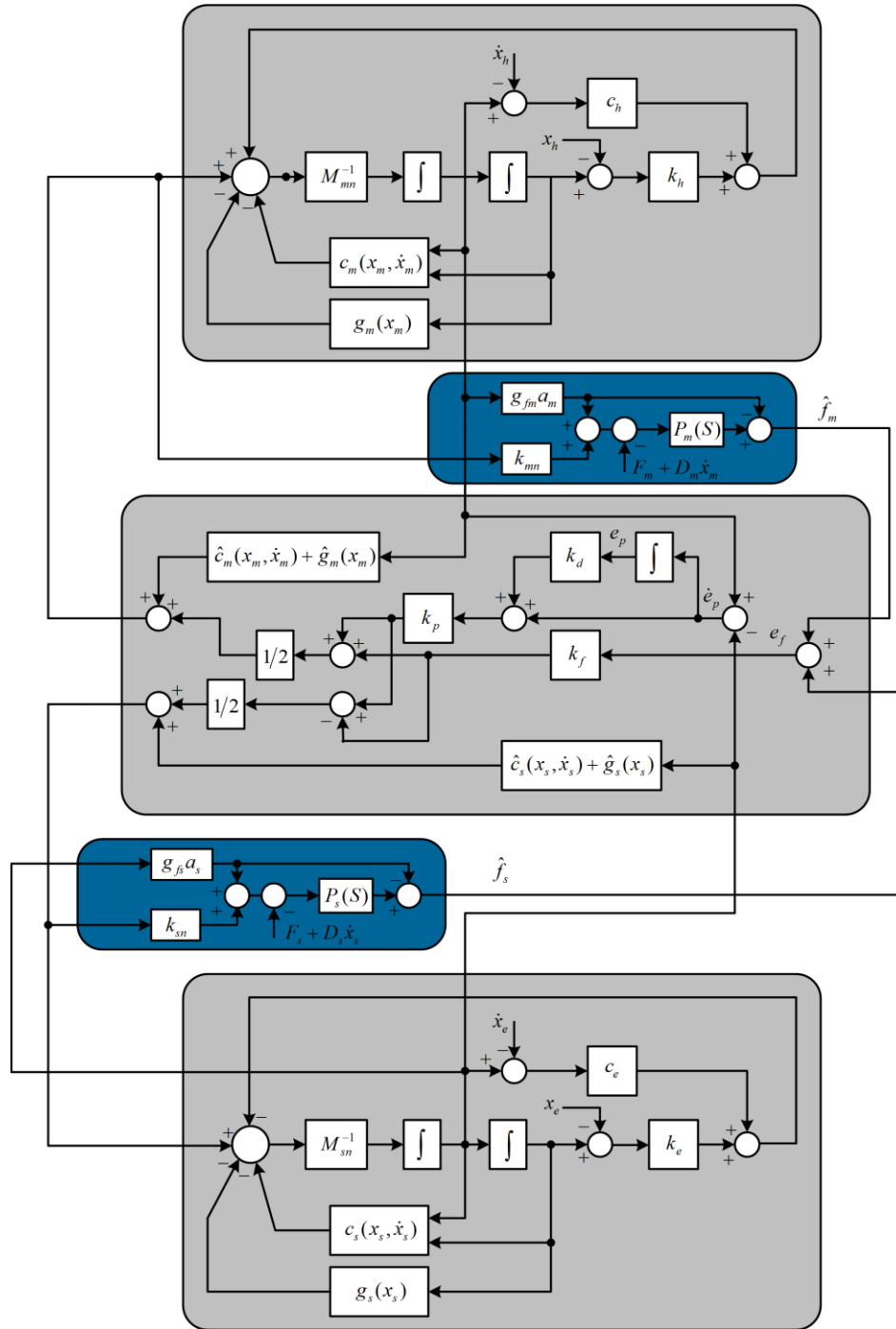

- Derive position and force tracking error dynamics of the system;
- Comment on your results.